



www.bikefixtation.com

2647 37th Ave. S Unit 1, Minneapolis MN 55406  
Phone: 612-568-3498 • E-mail: info@bikefixtation.com

---

## Installation Instructions for Bike Fixtation Deluxe Public Work Stand – Manual Rev. D



### **Street/Trail Setback Minimum:**

The setback for the Deluxe Public Work Stand is dependent on whether there is a Wheel Chock installed or not. See figure 1 and 2 for dimensions. If branding is part of the installation, the back of the repair stand should face the trail. If a Hoop Sign is installed, its location should be positioned based on each site.

# Site Layout for Bike Fixtation Deluxe Public Work Stand

## Minimum Space Requirements

The minimum space requirements for the Deluxe Public Work Stand are dependent on whether there is a Wheel Chock installed or not. See figure 1 and 2 for minimum space requirement dimensions. If branding is part of the installation, the back of the repair stand should face the trail.

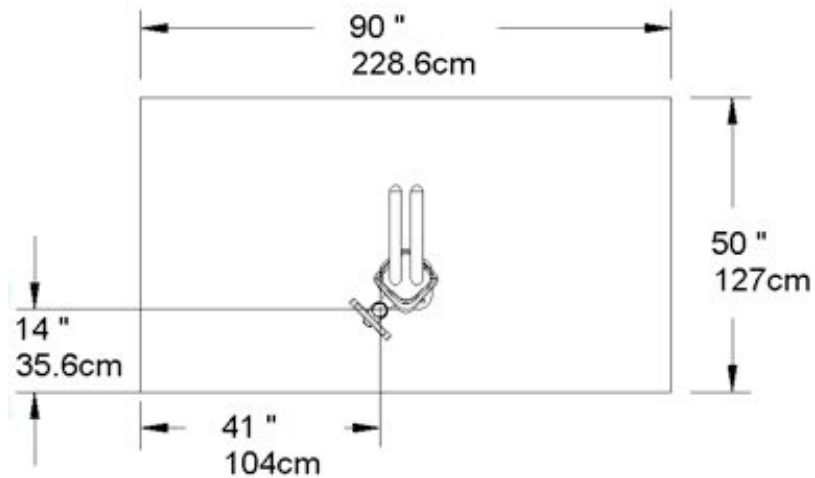

Figure 1: Minimum space requirements (without Wheel Chock)

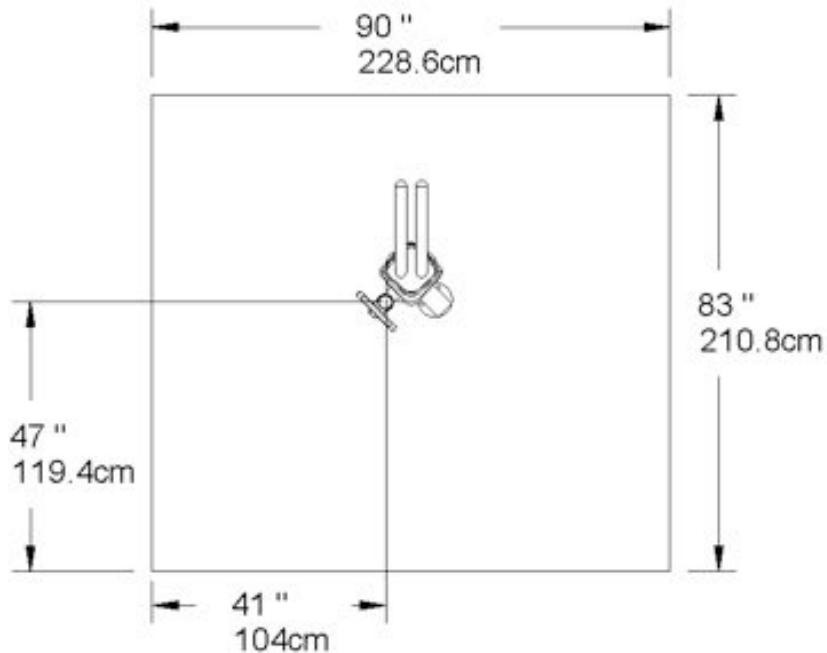

Figure 2: Minimum space requirements (with Wheel Chock)

## Setbacks

It is recommended that all equipment is spaced a minimum of 60" from an adjoining street or cycle path.

## Pad size

If you are pouring a new concrete pad, these are two recommended sizes. Option 1 is 36" x 36" x 4", option 2 is a 16" diameter cylinder that is 36" long.

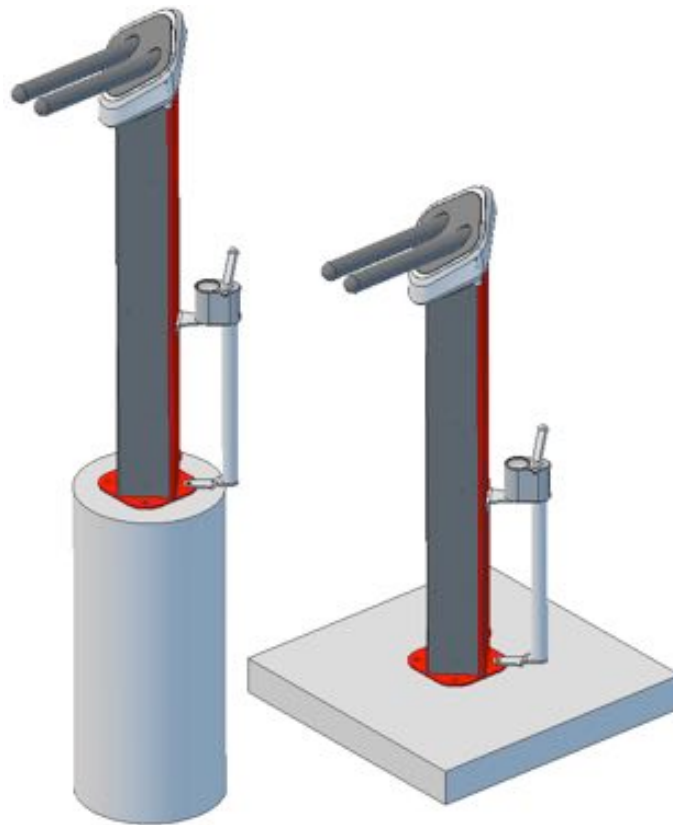

Figure 3: Recommended new pad configurations

## Tools Needed for Installation (Installer Provides)

Tape Measure  
½" Masonry Drill Bit Drill (Hammer drill recommended)  
Hammer  
3/8" drive ratchet and extension  
14mm (9/16") socket  
14mm (9/16") wrench  
19mm (3/4") wrench  
Marker or Pencil  
SAE hex key set  
Level

## Tools for Installation Provided with Equipment



Anchor Set Tool



\*Penta Security Socket



Concrete Anchor

2 button head hex bolts  
2 threaded concrete anchor studs  
2 Penta nuts (use with anchor studs)

**\*DO NOT THROW AWAY THE PENTA SOCKET AFTER COMPLETING THE INSTALLATION. YOU WILL NEED IT TO REMOVE THE EQUIPMENT IF THAT IS NECESSARY.**

**\*\*All manual pumps also come with a tube of lubrication for the pump's piston rod. See Appendix A for Bike Fixtation's recommended preventative maintenance schedule.**

## Installation

1. The Deluxe Public Work Stand ships in two separate boxes. If you purchased a pump or a Wheel Chock, those will be in extra boxes as well. Remove all parts from their boxes.
2. If your installation does not include a pump, skip to step 8. Tighten the threaded elbow fitting and the external hose onto the repair stand using a 14mm (9/16") wrench



Threaded elbow fitting



External hose

3. Connect the internal air hose to the elbow fitting by pressing it in until it bottoms out.



Internal air hose



4. Route the internal air hose into the side groove of the repair stand and have it exit at the pump mounting location (three circular holes). Connect the non-threaded elbow fitting to the hose by pressing it in until it bottoms out.



5. Prepare the pump by placing the long carriage bolts into the square holes on the mounting bracket and then insert into the round repair stand mounting holes.

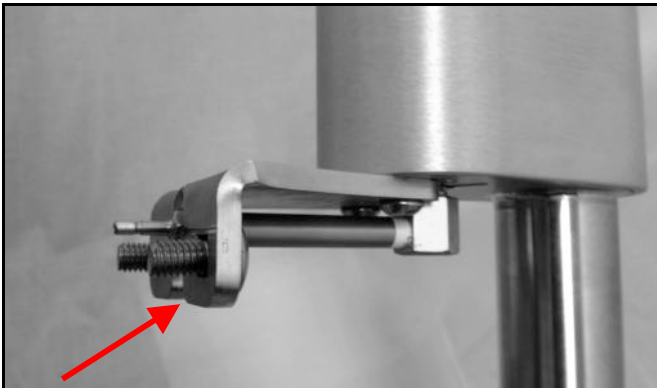

Mounting bracket

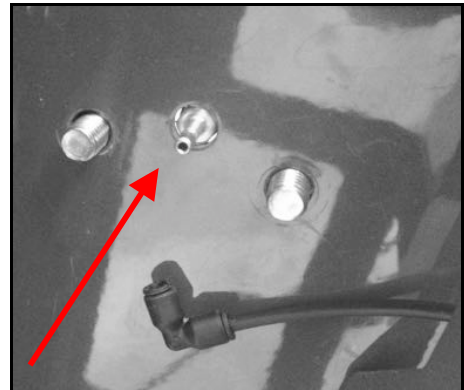

Pump outlet



Thin Jam Nut

Thin Jam Nut on Carriage Bolt

6. Tighten the Thin Jam Nuts onto the carriage bolts using a using a 14mm (9/16") and connect the elbow to the pump outlet. Next, install the weight guard and route the internal air line through the slot.



Thin Jam Nuts on Carriage Bolts

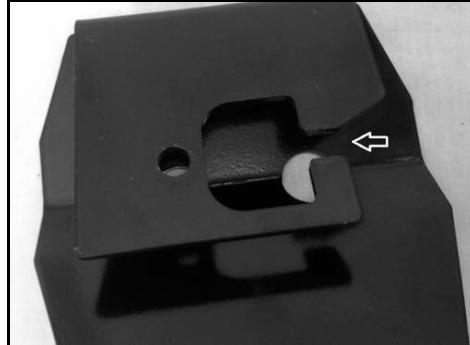

Weight guard

7. Thread the locknuts onto the carriage bolts using a 14mm (9/16") socket, extension, and ratchet



Lock nut

Lock nut on carriage bolt



8. If you are not installing a Wheel Chock, skip to step 9. Insert carriage bolts into the square mounting holes on the Wheel Chock and then insert into Wheel Chock mounting holes on the side of the repair stand. Tighten the lock nuts using a 14mm (9/16") socket.

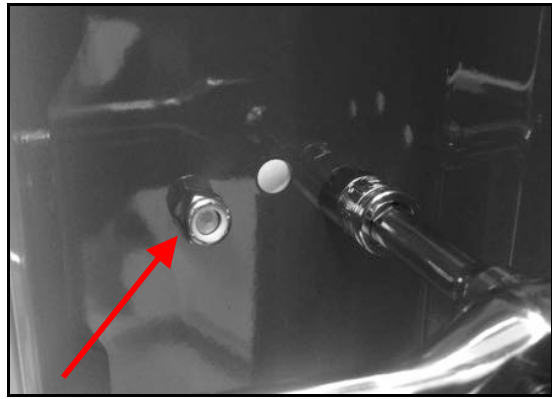

Locknut

9. Install the plastic cover. Start by feeding the bottom edges of the cover into the side grooves at the top of the stand and slide it down. Be sure it is seated into the slot at the base.





10. Install tool assemblies into base inserting the weights first. The tool assemblies and tool assembly carriage may be heavy for the person performing the installation. Avoid pinching fingers or hands when setting the tool carriage into place.

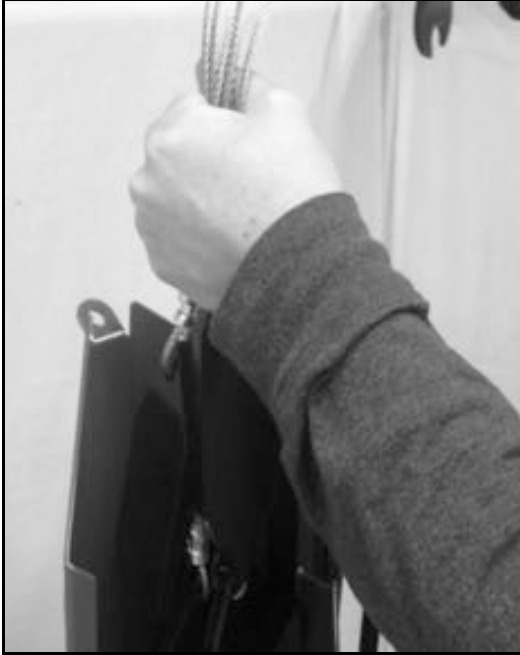

11. Check the cable routing to ensure that no tools are tangled. It is recommended that you pull on each tool to check for smooth operation.

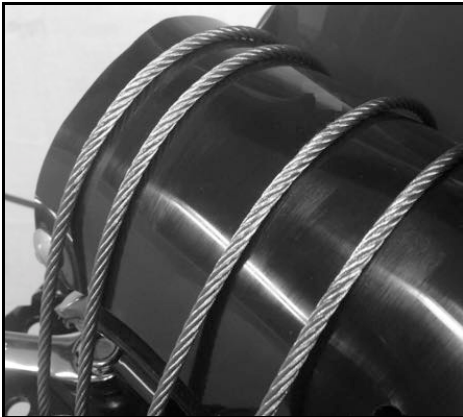

12. Tighten the large nut that secures the tool assembly carriage to the stand using a 19mm (3/4") wrench.



13. Install aluminum casting and then the top cap.



Aluminum casting



Top cap

14. Install and tighten the 2 front Penta nuts and Penta stud. Check the tightness twice of each. Do not over tighten these bolts.

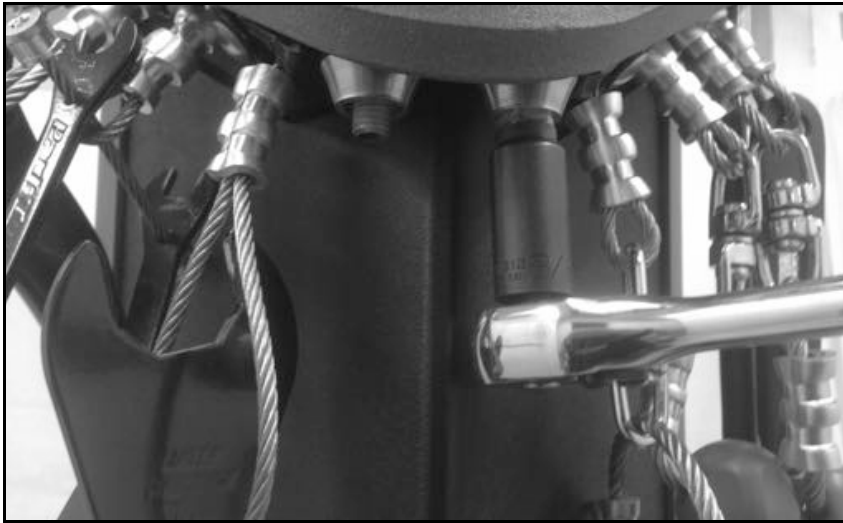

Front Penta nuts



Penta stud



15. Place the repair stand in the desired location (see setbacks on page 2). Use a marker or pencil to outline the holes of the flange onto the base material. We recommend checking the hole locations after each new anchor is placed. Ensure the holes are at least 6" away from any cracks in the base material.

16. The concrete anchor (a.k.a "drop in anchor") is a female anchor designed for use in solid concrete only and cannot be used in brick or block base material. The anchor size is designated by the inside diameter of the anchor. The Bike Fixtation Public Work Stand and Manual Pumps come with 3/8"-16 anchors. The diameter of the hole to be drilled is the same size as the outside diameter of the anchor which is 1/2".

17. When fastening to solid concrete with a drop in anchor, a hole must first be drilled into the concrete. A hammer drill should be used as it will drill the best quality hole. Once the bit is inserted into the hammer drill, the depth of the hole to be drilled can easily be set by using the depth gauge on the drill or by wrapping the bit with tape at the required depth. We recommend a drill depth of 1-5/8" deep so that the anchor just sets down flush with the surface.

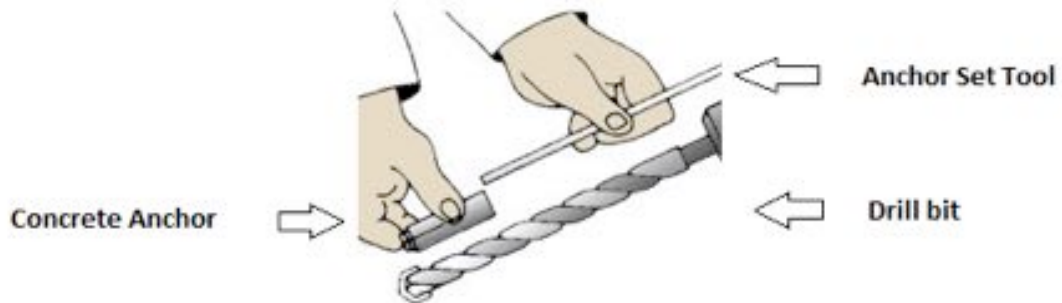

18. Before starting to drill the hole, it is important that eye and ear protection are used. Make sure the hammer drill is in the hammer mode and start drilling your hole. Continue drilling until the tape on the bit or the drill gauge meets the base material- this means that the required depth has been reached.

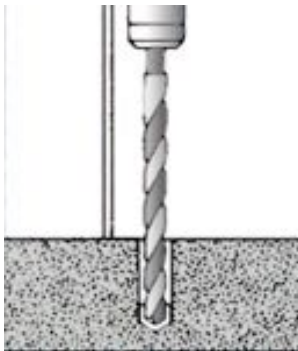

19. Before proceeding with installation, the hole must be cleaned of all concrete dust to ensure proper fastening. Use a wire brush, a vacuum or compressed air to clean out the hole completely.

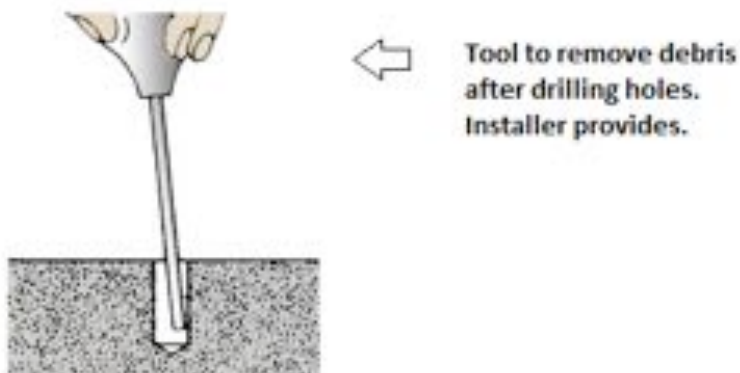

20. Next, insert the drop in anchor with the open side up. Tap lightly to get the anchor flush with the base material.
21. Now, take the setting tool and insert it into the anchor. Strike the setting tool with the hammer until the lip of the anchor touches the lip of the setting tool. This will ensure the anchor is properly set.

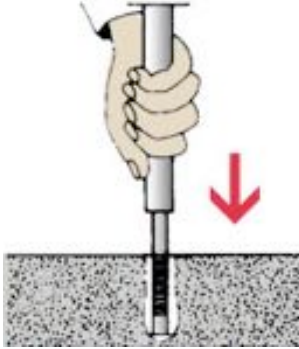

22. For the Public Work Stand - place the stand over the 4 anchors. You will be using 2 studs for the Penta nuts and 2 button head hex bolts (opposite sides from each other). You will thread the studs into the anchors prior to installing the Penta nuts using the Penta socket. Use the hex wrench to tighten the button head hex bolts.
23. Before tightening everything down, make sure the stand and/or pump are level and adjust accordingly with washers underneath the flanges.
24. Ensure all tools retract and extend properly. Cable routing could have shifted during shipping and needs to be adjusted by removing the repair stand top. Congrats! You're finished!

## Appendix A

Maintenance Item	Frequency	Time required
Pump head renewal	Every 3-12 months as required	2 minutes
Lubrication of pump rod	Every 6-12 months as required	2 minutes
Full pump overhaul	Every 24+ months as required	30 minutes

Tool Replacement	As required	15 minutes
------------------	-------------	------------

**\*For instructions on how to perform these tasks, please contact [sales@bikefixtation.com](mailto:sales@bikefixtation.com) for a copy of our High Security pump service manual.**