



www.bikefixtation.com

2647 37th Ave. S Unit 1, Minneapolis MN 55406
Phone: 612-568-3498 • E-mail: info@bikefixtation.com

Installation Instructions for Bike Fixtation

Wheel Chock – Manual Rev. A



Setback Minimum:

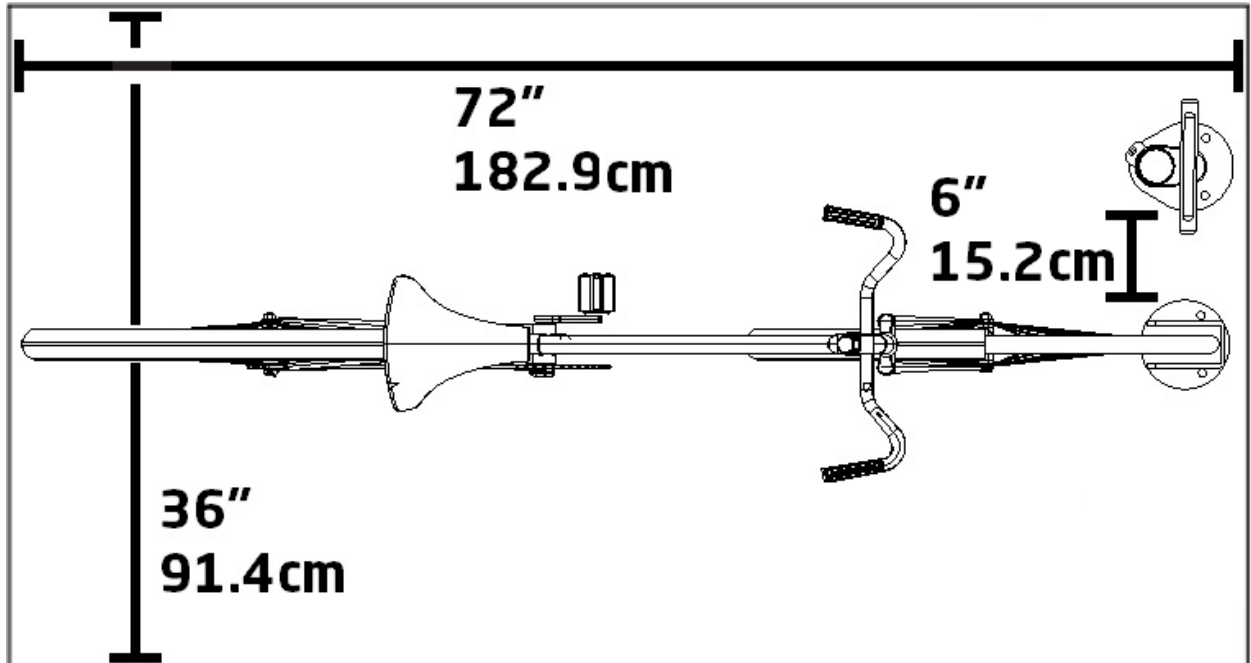

Figure 1: Setbacks

Tools Needed for Installation (Installer Provides)

Tape Measure
½" Masonry Drill Bit Drill (Hammer drill recommended)
Hammer
3/8" drive ratchet
Marker or Pencil
SAE hex key set
Level

Tools for Installation Provided with Equipment



Anchor Set Tool



*Penta Security Socket



Concrete Anchor

2 button head hex bolts
1 threaded concrete anchor studs
1 Penta nuts (use with anchor studs)

***DO NOT THROW AWAY THE PENTA SOCKET AFTER COMPLETING THE INSTALLATION. YOU WILL NEED IT TO REMOVE THE EQUIPMENT IF THAT IS NECESSARY.**

Installation

1. Place the wheel chock in the desired location (see setbacks on page 1). Use a marker or pencil to outline the holes of the flange onto the base material. We recommend checking the hole locations after each new anchor is placed. Ensure the holes are at least 6" away from any cracks in the base material.
2. The concrete anchor (a.k.a "drop in anchor") is a female anchor designed for use in solid concrete only and cannot be used in brick or block base material. The anchor size is designated by the inside diameter of the anchor. The Bike Fixtation Wheel Chock come with 3/8"-16 anchors. The diameter of the hole to be drilled is the same size as the outside diameter of the anchor which is 1/2".
3. When fastening to solid concrete with a drop in anchor, a hole must first be drilled into the concrete. A hammer drill should be used as it will drill the best quality hole. Once the bit is inserted into the hammer drill, the depth of the hole to be drilled can easily be set by using the depth gauge on the drill or by wrapping the bit with tape at the required depth. We recommend a drill depth of 1-5/8" deep so that the anchor just sets down flush with the surface.

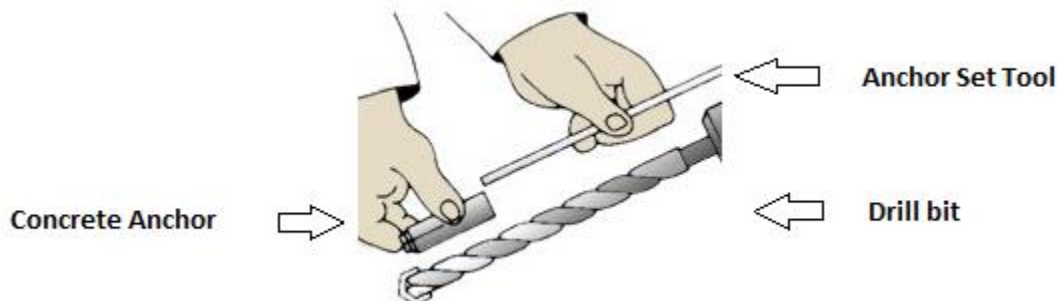

4. Before starting to drill the hole, it is important that eye and ear protection are used. Make sure the hammer drill is in the hammer mode and start drilling your hole. Continue drilling until the tape on the bit or the drill gauge meets the base material- this means that the required depth has been reached.

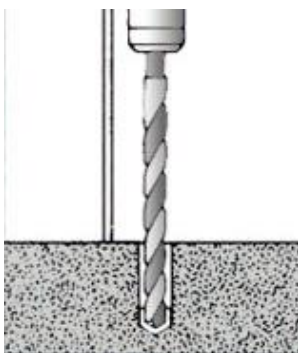

5. Before proceeding with installation, the hole must be cleaned of all concrete dust to ensure proper fastening. Use a wire brush, a vacuum or compressed air to clean out the hole completely.

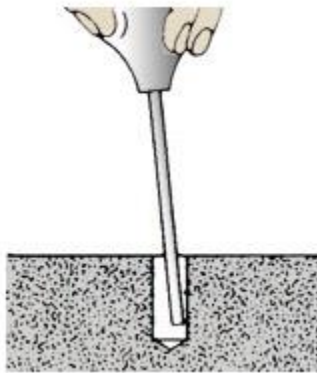

**Tool to remove debris
after drilling holes.
Installer provides.**

6. Next, insert the drop in anchor with the open side up. Tap lightly to get the anchor flush with the base material.
7. Now, take the setting tool and insert it into the anchor. Strike the setting tool with the hammer until the lip of the anchor touches the lip of the setting tool. This will ensure the anchor is properly set.

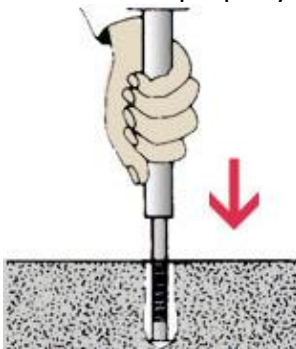

8. For the Wheel Chock - place the Wheel Chock over the 3 anchors. You will be using 1 studs for the Penta nut and 2 button head hex bolts. You will thread the stud into the anchor prior to installing the Penta nuts using the Penta socket. Use the hex wrench to tighten the button head hex bolts.
9. Before tightening everything down, make sure the stand and/or pump are level and adjust accordingly with washers underneath the flanges.
10. Ensure all tools retract and extend properly. Cable routing could have shifted during shipping and needs to be adjusted by removing the repair stand top. Congrats! You're finished!