



Cyclepods

Transforming bike storage



CYCLEPODS IN EDUCATION

Cyclepods in Education

Cyclepods have now supplied bike and scooter storage to over 2,500 nurseries, primary and secondary schools in the UK, so we feel extremely confident saying that when it comes to cycle parking within education, we have a solution that not only secures bikes in the most space efficient way but will also encourage children to travel to school sustainably!

Our products are perfect for learning environments, due to their vibrant colours and unique styles. We firmly believe in encouraging sustainable travel in schools and have designed these products with this in mind. In order to teach children how to be safe and responsible when travelling by bike or scooter, there are simple and easy to use locking points on the Minipods & Scooterpods so children can practice safe locking practices with any type of bike lock.

At Cyclepods we have a team of experienced designers who can help with planning your cycle storage to ensure space efficiency and maximum usage. Our in house installation team (we do not use contractors) will ensure our products are installed safely, securely and will always consider the environment they are in. For instance, if we are installing at a primary school, any drilling work will only be considered when the children are inside the school. We will also pause installation whilst the children are out in the playground to ensure their safety.

And of course our resident Minipod and Scooterpod Queen, Jan Robinson, is always ready to help you and your school find the best solution for cycle and scooter parking!



Minipods

The Minipod is a fun, colourful and compact cycle storage design which secures 8 bikes and 8 scooters. Available in a range of different colours, the Minipod is ideal for primary schools encouraging cycling and the children love them!

The Minipod has been designed to fit 12"-26" wheels, so is specifically aimed at children up to 11 years of age; ideal for primary schools, but can cater for the occasional teacher/adult bike with 26" wheels.

At less than 1.5 meters in diameter, the Minipod not only saves space, but appeals to children by offering a colorful, innovative and playful design.

Minipods are also sustainable products with a fully recycled model available (in black). We offer a selection of colour options all of which are 100% recyclable. There are now over 18,000 bike spaces in schools across the UK provided by Minipods!



Colour Options



Case Study: Brabin's Endowed School, Lancashire

"When I attended the Eco Schools conference in Aintree at the end of June, members of our Eco-Schools Committee saw the Minipods on the Cyclepods stand and steered me towards them saying "This is exactly what we need".

Following the purchase of our Minipod in August, I can safely say that the Minipod was indeed what we needed. Not only is the product aesthetically pleasing, it's perfect for the job it's designed to do. Its presence is in keeping with our ethos, it adds a new dimension to sustainability within schools. Ordering our Minipods was straightforward and Cyclepods personnel were most helpful.

We wanted our pupils to get really involved with the purchase of this piece of playground furniture so we held a naming ceremony, which resulted in 'Percival Peregrine Pod' (PP to his friends) arriving on site. (This adds a fun element and Percival now proudly sits close to our 'Green Monster' – the paper skip)

Our Minipod has encouraged children to cycle to school accompanied by parents so helping us achieve our aim to promote a healthy life style whilst reducing the number of vehicles parked outside the playground at the beginning and end of the school day. (There are also aims of Eco-Schools, Healthy Schools and Cyclepods who supply Minipods.)

The product is a great design, being very attractive to young children of primary school age. It's low maintenance, being made of colourful recycled plastic. It has no rust factor or sharp parts that could cause injury (Unlike traditional cycle racks and sheds that sometimes get used as a climbing frame)

The shape of the Minipod has allowed us to put it in a space not previously considered as having any purpose, which is great. This means that we've been able to site the Minipods amongst other playground furniture taking up very little space and adding to the overall sustainable environment of our school. The Minipod is now full up with bikes and scooters every day and we are looking at purchasing a second...what shall we call this one?"

Glynis Goldberg, Former Headteacher

Bethany: "I think the Minipod is really good because it gives me somewhere to park my bike so that it does not fall down and allows me to get my bike easily after school."



Mum Judith: "We really appreciate the school supplying a Minipod because it keeps the bikes upright. It holds quite a few bikes and scooters and beats by far the old way we stored bikes against a tree. They are perfect for the children. Very easy to use and look good too."

Ben: "I like to cycle to school because it gives me lots of exercise and it is fun. Percival Pod makes it easy for me to park my bike safely and easily and is very useful. My favourite thing about it is that it is easy to use because you just put your bike into it."



Scooterpods



The Scooterpod is a unique storage solution just for scooters! The fun and colourful innovation is ideal for nursery and primary schools, securing 10, 11, 12 or 24 scooters in different configurations! Like all Cyclepods' products, the Scooterpod is manufactured in the UK and available in 100% recycled materials.

We have recently adapted the design of the original Scooterpod so linear segments are now available. Each segment of a round or linear Scooterpod holds 5 scooters, two linear segments can be placed side by side against a wall to give 11 spaces or back to back to give 10 spaces. Two round segments placed together give 12 scooter spaces, or you can combine the linear and round segments to create a Scooterpod Island which holds up to 24 scooters!

All versions of the Scooterpod can be placed on a freestanding base to be put on grass or a soft surface, alternatively they are easy to bolt into a concrete or tarmac surface using the bolts supplied. Plus they come in a great range of colour options!

Colour Options



Case Study: Derbyshire County Council & Travel Smart

If you scoot to school
around the playground don't race!
Instead walk with your scooter
and park it in a safe place.



Picture from 2016 Travel Smart Week 'Monster Move' Campaign - Derbyshire County Council

"Here in Derbyshire lots of children like to scoot to school which is fantastic as it helps to support active and environmentally friendly ways of travelling to school.

We do lots of work to encourage scooting to school including Scooter Smart – a training session, often involving local police and neighbourhood team officers from Derbyshire Constabulary, to promote the safe use of scooters on the pavement, as well promoting scooting to school as part of our twice yearly Travel Smart campaign.

While scooting to school is popular – having to carry the scooter home is not! To ensure scooting and cycling to school is a viable travel option having somewhere to store your wheels is vital!

As part of work to promote active travel many schools in Derbyshire have chosen Scooterpods and Minipods as the storage solution for scooters and bicycles.

In partnership with Modeshift we've also been able to offer Scooterpods from Cyclepods as prizes to schools as a great incentive to encourage participation in our Travel Smart campaigns to help reduce the traffic congestion on the school run."

Rob Bounds, Senior Transport Officer, Derbyshire County Council

Streetpod

If you have any security concerns about bikes at your school for staff or those in secondary education, the Streetpod is your answer.

The Streetpod has undergone a rigorous testing process to achieve a Sold Secure Silver security rating as well as Secured by Design accreditation. In fact it is the only freestanding cycle parking product to have achieved both Sold Secure Silver and Secured by Design recognition, this is due to its unique 'one lock secures the whole bike' feature. This makes the Streetpod one of the most secure cycle parking products available.

Unlike traditional racks and Sheffield stands, no groundworks are necessary for Streetpods and they can be bolted down onto tarmac or concrete, saving time and money with no planning permission required.

They also save approximately 30% space compared to standard bike stands and, like the Cyclepod, the MDPE body is made from 100% recycled materials. Available in a wide range of colours, including stone effect finishes, the Streetpod is easily adaptable to fit in with your surroundings, add an aesthetic touch to your building or stand proud in school colours!

In addition to this we have tested Streetpods against fire damage and graffiti. Graffiti washes off with a sponge dipped in warm water with washing up liquid. Scratches on the Streetpod can be rubbed out with sand paper due to the consistency of the MDPE body (whatever colour) and it has also proved itself to be resistant to minor fire damage.



Case Study: Vyners School

At Vyners School in Hillingdon we installed 60 Streetpods under 12 Canterbury Shelters in one linear formation. The previous cycle storage was outdated and poorly maintained, with rusty semi-vertical racks that were mainly unusable and damp, dark shelters covered in rubbish and debris.

The school decided that they needed to upgrade their cycle storage to encourage cycling as part of the Hillingdon Borough Council Sustainable Travel Initiative, they already had a high number of students and teachers cycling but concerns over safety and security were an issue. Due to the semi-open space they had available, Streetpods were the favourite choice of parking because of the Sold Secure rating.



BEFORE

Cyclepods uninstalled and disposed of the previous shelters and racks and installed the bright, new Streetpods in their place without the need for major groundworks. Vyners School opted to make a statement of their new bike storage by selecting red and dark green Streetpods to match the school colours!



AFTER

Shelters, compounds & lockers

We understand that sometimes a more traditional option is preferred which is why we have a huge range of stands & shelters to choose from. Other additional products like kit lockers for helmets and trainers are also available so the children have somewhere to keep their belongings after cycling to school.



As well as shelters and racks we also offer a solution for specially adapted bikes and trikes which are popular at SEN schools. The Lockerpod+ holds up to 4 bikes so has plenty of room for adapted cycles, it shares the same eco-friendly credentials as the Minipods & Scooterpods as it is also made from recycled & recyclable MDPE. The standard Lockerpod+ model is rated Sold Secure Bronze and is available in Sold Secure Gold which comes with a special ground anchor for locking bikes to. And it is available in a wide range of colours!



CANTERBURY SHELTER



CYCLE SHELTER DESIGNS

Some of our shelter roofs are designed in such a way that algae, tree sap or rubbish can't be seen from below and thus avoiding service quality fails or high level maintenance.

Sheltered bike racks can be securely enclosed with fencing and lockable gates.

Traditional options don't have to be boring either! We offer powder coating for all our stands, racks and shelters which can be bespoke to your school colours.

OXTED SHELTER



HARROGATE SHELTER



TFL Cycle Parking Provision Scheme

Since 2012 we have won yearly tenders for TFL's Cycle Parking Provision Scheme which provides cycle and scooter parking across TFL Schools.

Under these contracts we have now delivered 700 bike and 4,140 scooter spaces to 156 primary schools throughout London and Greater London including enabling civil works. The high demand for bike & scooter storage only goes to show the fantastic increase in cycling and scooting to school and how many children are championing the trend!

We started with our Minipods & Scooterpods but in more recent years this has been extended to our fabulous Minipod shelters (also known as Oxted shelters), as well as other traditional options.

With each school that applied for storage under the TFL Scheme, we carried out site specific surveys to evaluate the number of spaces requested against the area allocated for the products. We then produced detailed CAD drawings to ensure space was maximised and the school were able to get as many bike and scooter spaces as possible!

These site visits also doubled up as an H&S survey which allowed us to produce site specific RAMS for each school. We conducted a customer satisfaction survey with all schools after installation and received an average score of 9.5 out of 10 for service, installation and quality.

As of 2016, Cyclepods have renewed their contract with TFL to provide even more schools across London with the following products;

Minipods

Scooterpods, including Scooterpod Islands!

Oxted (Minipod) Shelters

Canterbury Shelters

Toast Racks

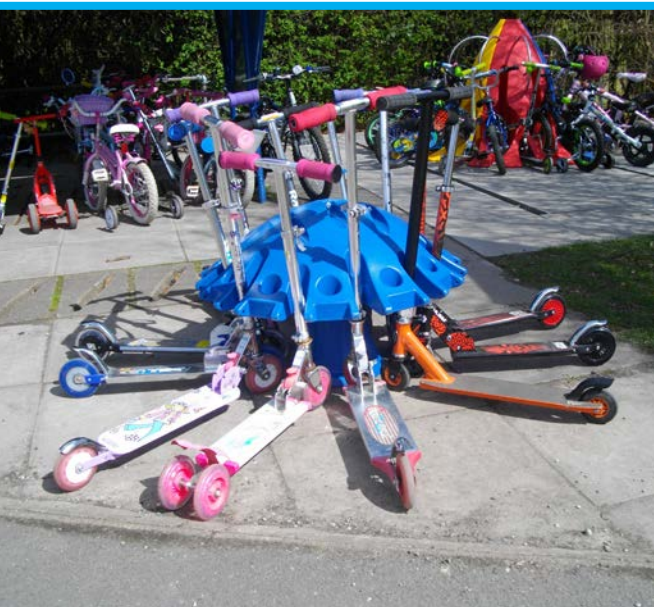



Modeshift is the UK's leading sustainable travel organisation who exist to share best practice in sustainable travel delivery. Since 2008 we have partnered with Modeshift to provide cycle and storage through Local Authorities who are Modeshift members. As part of this we offer discounts on Minipods, Scooterpods & Streetpods to all members as well as all schools within a member's local authority!

We also give away a free Scooterpod to each member every year that they can use as prizes for competitions, initiatives or simply to give a school a running start at sustainable travel.

Modeshift have launched a new initiative for schools called Modeshift STARS. Schools that sign up to the STARS programme can work to achieve Bronze, Silver & Gold accreditation and win all sorts of prizes of funding opportunities along the way!

In 2015, 347 schools nationally have achieved Modeshift STARS accreditation in recognition of their efforts to encourage their pupils to travel to school in greener, healthier and safer ways, and now the very best of those schools has been announced.

Over 200 people including teachers and pupils attended three regional awards events that were held during October. At those three events, six Schools of the Region were recognised for their outstanding achievements in increasing levels of sustainable and active travel.

In March 2016 all six regional winners were invited to the Houses of Parliament where one was crowned the National School of the Year!

“The STARS scheme recognises schools that have demonstrated excellence in supporting cycling, walking and other forms of sustainable travel. The schools that have been recognised as Schools of the Region have achieved way beyond what is expected of them and as such, are able to demonstrate some incredible results. They are a shining example to all of us and prove that we really can make a difference to the journey to school”.

Ross Butcher, Chair of Modeshift



For the last 6 years Cyclepods have sponsored the Sustrans Big Pedal by donating prizes to the winners. In the past few years, we have offered the option of a Minipod, Scooterpod or Streetpods to Big Pedal Winners!

Over 1,280 schools, with more than 400,000 pupils, across the UK have so far signed up to the annual inter-school competition which in 2016 took place between 18th and 29th April. Run by charity Sustrans, the Big Pedal sees schools compete to see who can record the greatest number of pupils, staff and parents cycling and scooting to school. For more information on the Big Pedal visit -

www.sustrans.org.uk/bigpedal.



We love to support organisations like Modeshift and Sustrans and their initiatives such as Big Pedal & Modeshift STARS because the driving force behind our company is to promote cycling and other forms of sustainable travel and think that nowhere is this more important than in schools, to encourage the next generation of cyclists!

MINIPOD

The Minipod is a unique product designed to get children cycling. The Minipod is an innovative product which allows 8 bikes and 8 scooters to be secured.

Available in a range of different colours, the Minipod is ideal for primary schools encouraging cycling and the children love them!

There are now over 2500 Minipods installed at schools across the UK!

They can be placed on their own, in halves against a wall or on portable bases and mats!

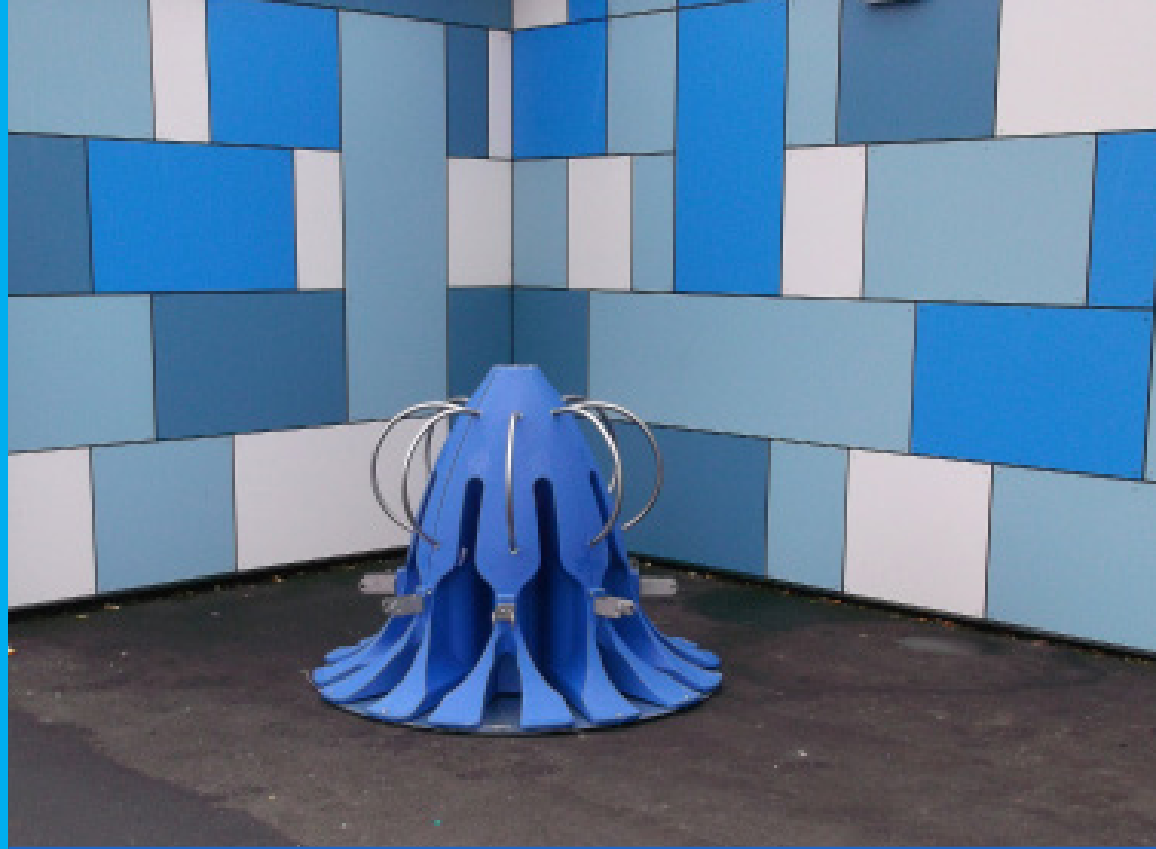

Product Name: Minipod Quadrant

Material: 100% Recyclable MDPE plastic.
100% Recyclable and 100% Recycled MDPE plastic (black).

BREEAM: Our Scooterpods have been used successfully within BREEAM schemes throughout the UK.

Panel Thickness: 14 mm. Outer lower rim 20mm high. 60mm channel/track width to cater for 99% of all standard European tyre width's.

Panel Finish: Dimpled effect finish

Panel Weight: 5kg each. Overall weight 75Kg.

Securing Arms Material: Recycled Grade Stainless Steel.

Number of securing arms: 8 Upper arms (for bikes). 8 Scooter securing arms

Securing Arms thickness: 2mm thick walled tube. Scooter securing thickness 5mm.

Top Plate Material: 5mm Stainless steel.

Fixing Method for Securing Arms: Nyloc nut and Washer. All housed internally so no visible fixings.

Fixings Material: All standard Cyclepod fixings are Stainless steel. Ground anchors are nickel plated.

Ground Fixings Required: 16mm outer diameter shield anchor bolts drilled to a depth of 100mm max. 2 fixing bolt required per quadrant.

Ground Type Required: Solid level base required. Concrete, large slabs etc.

Optional Items: Canopy, Base, Mats

Product Code: MINI001

Colour Options: Black, Red, Yellow, Royal

MINIPOD ELEVATION

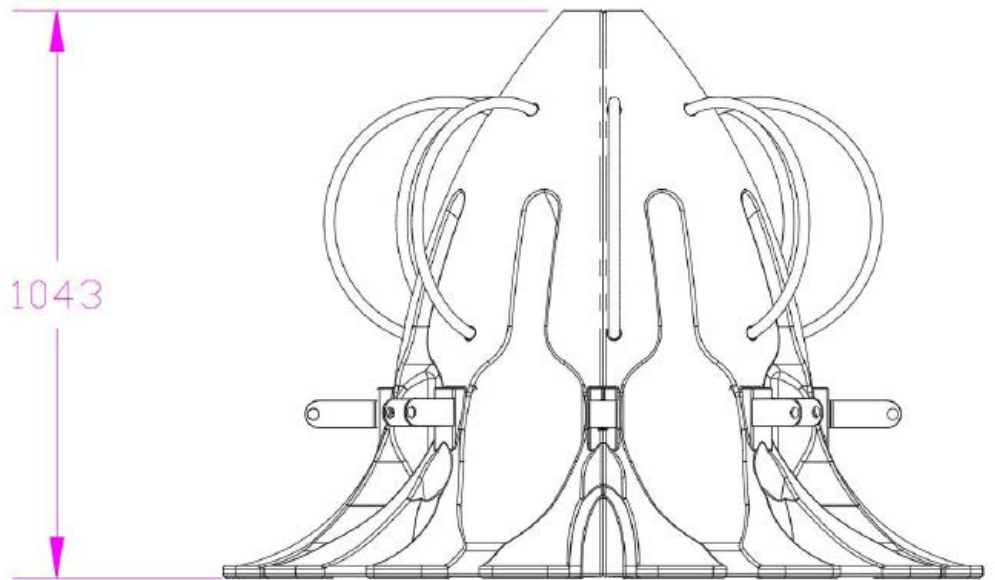

MINIPOD FIXING DETAIL

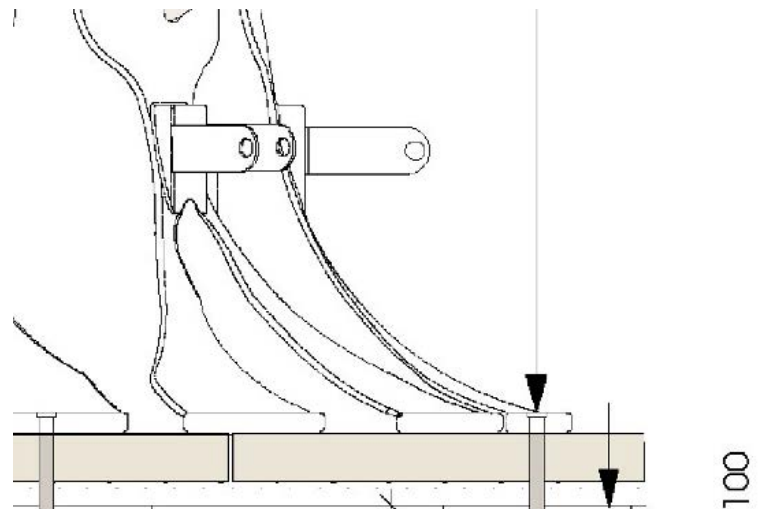

MINIPOD PLAN

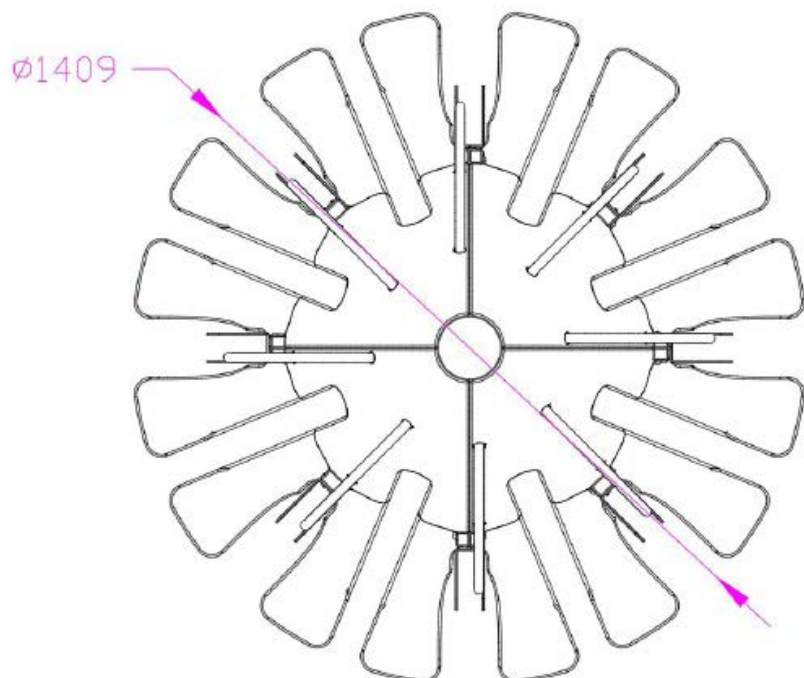

SCOOTERPOD

The Scooterpod is a unique and compact storage solution just for scooters! The fun and colourful innovation is ideal for nursery and primary schools, securing up to 12 scooters!

Like all Cyclepods' products, the Scooterpod is manufactured in the UK and available in 100% recycled materials. The Scooterpod; another space – saving, secure and eco-friendly design which doesn't require foundations!

Combine it with the Linear Scooterpod to form Scooterpod Islands!



SCOOTERPOD 3D VIEW

Product Name: Scooterpod

Material: 100% Recyclable MDPE plastic (colours, Red, Blue, Yellow, Green). 100% Recyclable and 100% Recycled MDPE plastic (black).

BREEAM: Our Scooterpods have been used successfully within BREEAM schemes throughout the UK.

Part Thickness: 14 mm.

Part Finish: Black, Blue, Yellow, Green, Red. Dimpled effect finish, gloss.

Part Weight: 6kg each. Overall weight 12Kg.
Scooter Slots: Up to 12

Fixing Method for Assembly: Nyloc nut and Washer.

Fixings Material: All standard Scooterpod fixings nickel plated.

Ground Fixings Required: 10mm outer diameter resin anchor bolts drilled to a depth of 100mm max. 3 fixing bolts required per half.

Ground Type Required: Various

Optional Items: Canopy, Base, Mats
Product Code: SCO001

Colour Options: Red, Yellow, Blue, Green, Black (recycled), Multicolour.

Various shelter options available for all products.

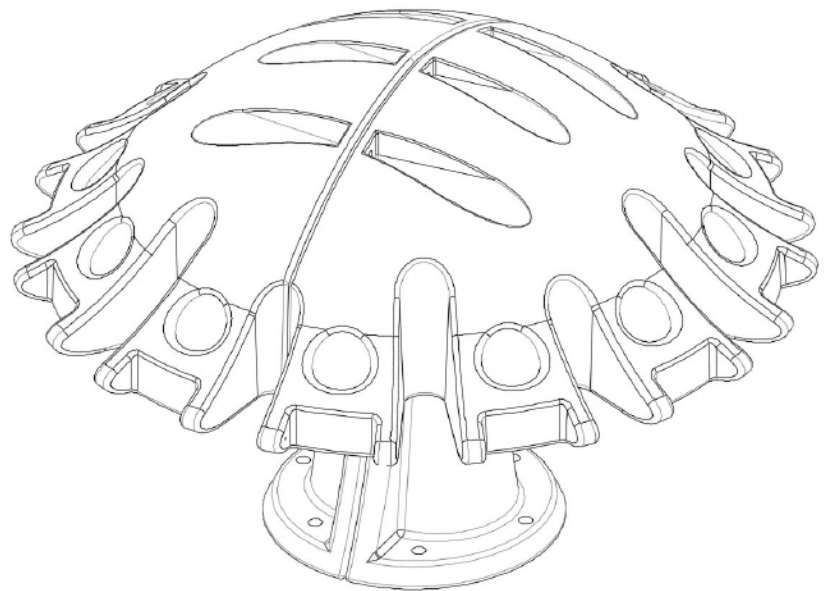

SCOOTERPOD SPACE REQUIREMENTS

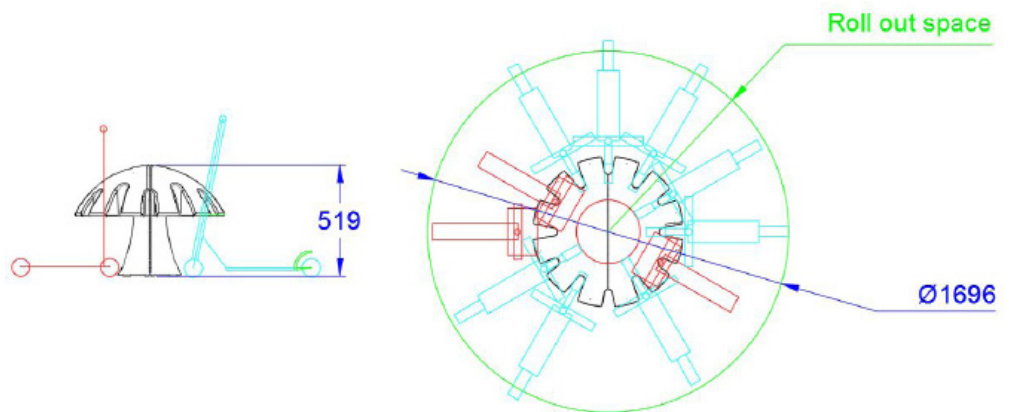

SCOOTERPOD WALL MOUNT OPTION

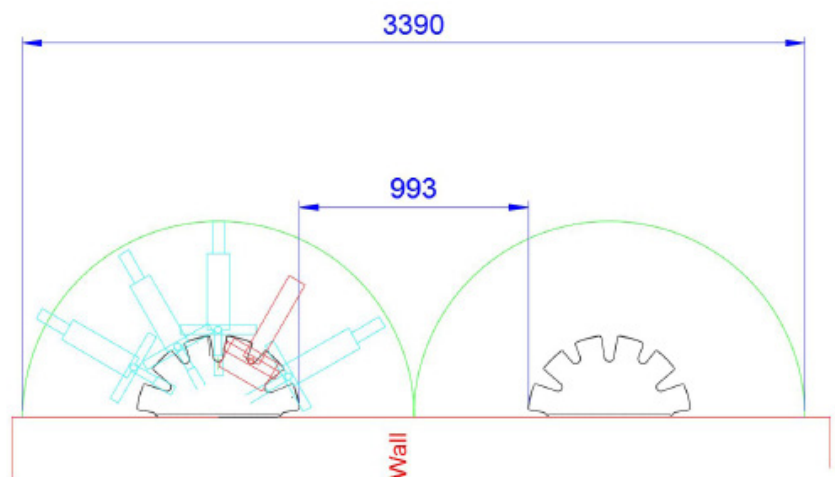

LINEAR SCOOTERPOD

The Linear Scooterpod is a unique and compact storage solution just for scooters! The fun and colourful innovation is ideal for nursery and primary schools, securing 5 scooters per segment!

Like all Cyclepods' products, the Scooterpod is manufactured in the UK and available in 100% recycled materials. The Scooterpod; another space – saving, secure and eco-friendly design which doesn't require foundations!

Combine it with the Scooterpod to form Scooterpod Islands!



LINEAR SCOOTERPOD 3D VIEW

Product Name: Linear Scooterpod

Material: 100% Recyclable MDPE plastic (colours, Red, Blue, Yellow, Green). 100% Recyclable and 100% Recycled MDPE plastic (black).

BREEAM: Our Linear Scooterpods have been used successfully within BREEAM schemes throughout the UK.

Part Thickness: 14 mm.

Part Finish: Black, Blue, Yellow, Green, Red. Dimpled effect finish, gloss.

Part Weight: 6kg each. Overall weight 12Kg. Scooter Slots: 5 per segment

Fixing Method for Assembly: Nyloc nut and Washer.

Fixings Material: All standard Scooterpod fixings nickel plated.

Ground Fixings Required: 10mm outer diameter resin anchor bolts drilled to a depth of 100mm max. 3 fixing bolts required per half.

Ground Type Required: Various

Optional Items: Canopy, Base, Mats
Product Code: SCO002

Colour Options: Red, Yellow, Blue, Green, Black (recycled), Multicolour.

Various shelter options available for all products.

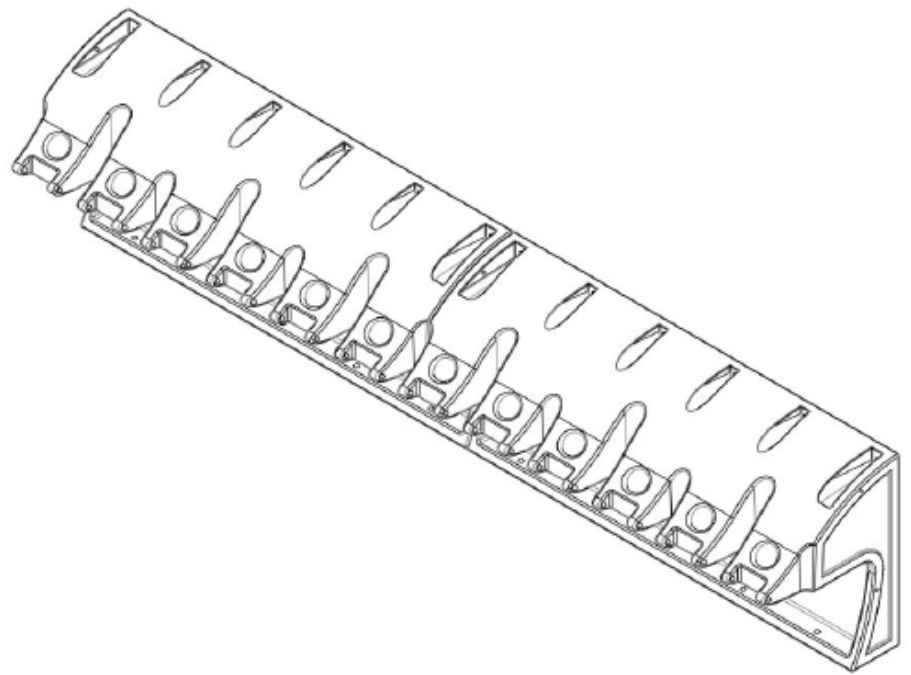

LINEAR SCOOTERPOD SPACE REQUIREMENTS

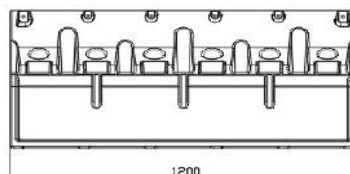
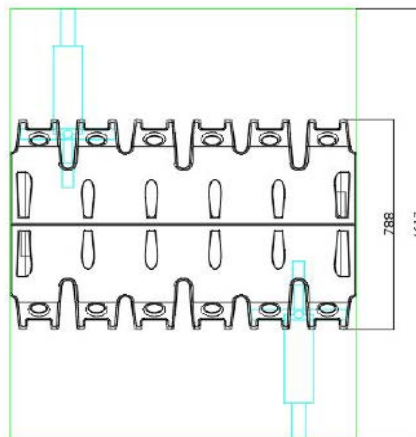

LINEAR SCOOTERPOD BACK TO BACK OPTION

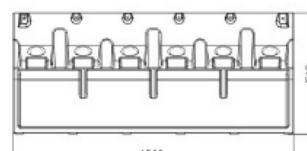
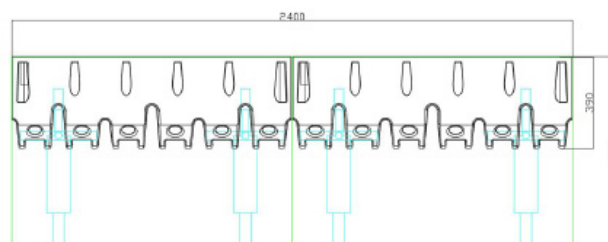

STREETPOD

The Streetpod is our latest revolutionary cycle storage design! This highly secure and stylish product offers maximum bike protection for public location and open spaces, where bike security is a concern.

The Streetpod is Secured by Design accredited and UK police recommended, it is also the only freestanding cycle parking solution in the UK which has achieved Sold Secure Silver certification.

The front wheel is housed within the security shield which prohibits it from being removed.

The Streetpod has the ability to secure the bike frame and both wheels with a single lock. This highly configurable design can also accommodate advertising and sponsorship.



STREETPOD SPACE SAVINGS

BREEAM/CODE for Sustainable homes bike stand layout

Space required = 16.8 square meters

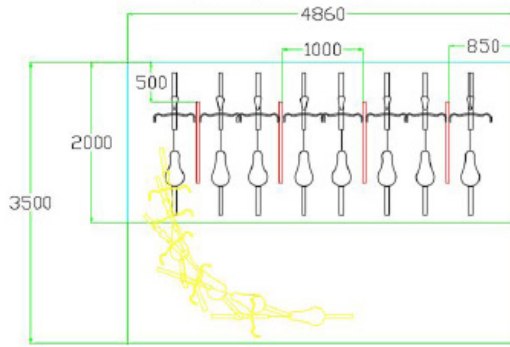

BREEAM/CODE for Sustainable homes Streetpod layout

Space required = 10.85 square meters

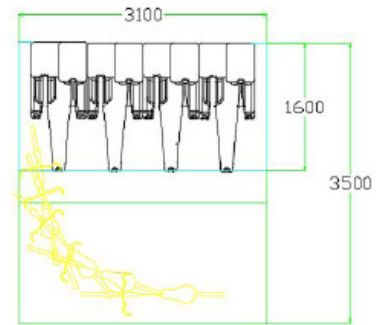

— Roll out space required
— Static space required
— Bike in roll out position

Streetpod- 35% less space used

Product Name: Streetpod—SBD

Panel Material: Medium density polyethylene (MDPE), Black version is recycled and recyclable, where as colour versions are just recyclable.

Wall Thickness: 7-9 mm. 65mm channel/ track width to cater for 99% of all standard European tyre width's.

Finish: Dimpled effect. Standard colour black, other colours available at additional cost.

Product Weight: 20kg each.

Securing loop: Galvanised Steel as standard, Stainless steel option available.

Securing loop thickness: 50 mm diameter, with 3.2mm thickness . 20mm solid securing bar.

Fixing Method for loop Arms: Fixed to floor using ground anchors/resin.

Fixings Material: All standard Streetpod fixings are Galvanised/Stainless steel. Ground anchors are nickel plated.

Ground Fixings Required: 3 types: 16mm outer diameter shield anchor bolts drilled to a depth of 100mm max . Self using M14 Sheer off nuts and resin. 5 fixing bolt required per Streetpod

Ground Type Required: Solid level base required. Concrete, large slabs with minimum 50mm thickness

Internal fixings: Shear off nuts + Loc tight to be used on all internal fixings.

Product Code: STREET001

Colour Options: Standard in Black (Recyclable) Red, Yellow, Royal Blue, Light Blue, Dark Green, Light Green, Grey, Stone effect and multicolour available.

STREETPOD DIMENSIONS

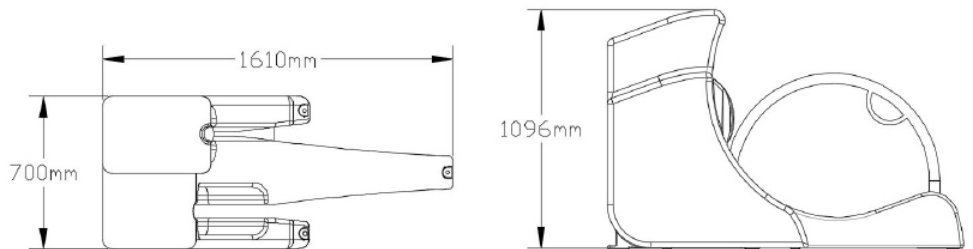

STREETPOD 3D VIEW

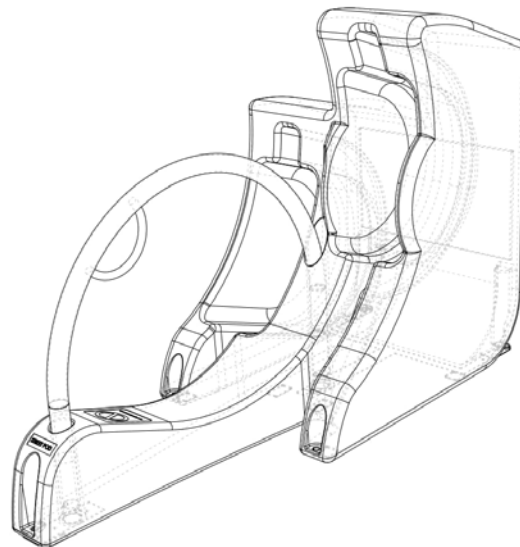

HOW TO LOCK YOUR BIKE TO THE STREETPOD:

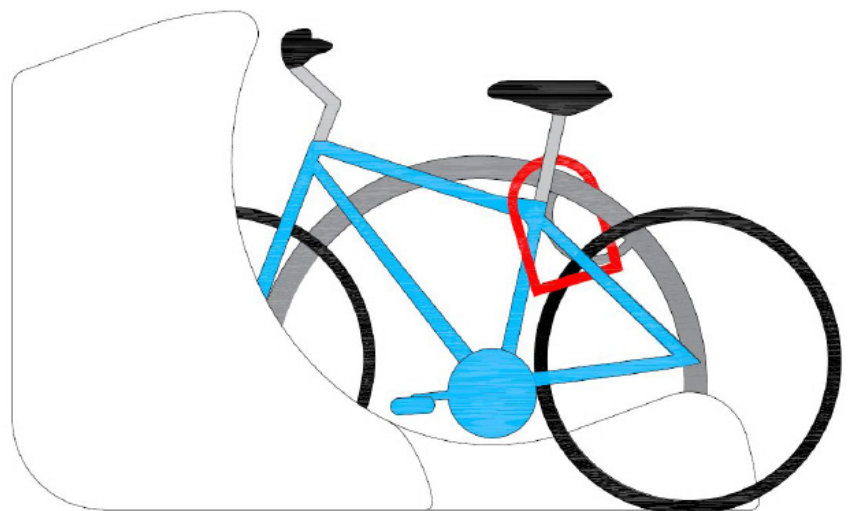

OXTED SHELTER

The Oxted Shelter was designed as a versatile shelter for our Minipod, but can also be used to shelter up to 4 Scooterpods, or as a colourful parent waiting shelter!

The shelter is multi-coloured as standard but can be painted to suit your school colours!

Specification:

Shelter manufactured from hot dipped Galvanised steel 50 x 50 box section to BSEN ISO1461
Transparent PET 4mm roof
Aluminium fixing straps
All fixings to be galvanised or aluminium
Nyloc nuts are used for safety
Curved roof

Installation Notes:

Two ground fixing options
Base plate fixing
Submerged fixing

Additional Information

Dimensions: L 360cm x D
360cm x H 220cm
Weight: 180kg



CANTERBURY SHELTER

Product Name: Canterbury Bike Shelter

Product Description:

Bream and Code for Sustainable Homes Compliant

This bike shelter can help contribute towards gaining ENE8 Cycle storage credits when used in the appropriate situation, under the Code for Sustainable Homes.

Specification :

Shelter manufactured from hot dipped steel Galvanised 50 x 50 box section to BSEN ISO1461

Transparent PET 4mm roof

Optional Transparent PET 4mm sides

Aluminium fixing straps

All fixings to be galvanised or aluminium

Nyloc nuts are used for safety

Anti climb end panels

No crawl under perimeters.

Angled roof

Installation Notes

Two ground fixing options-

Base plate fixing

Submerged fixing

No Cycle racks provided

Additional Information

Weight: 99kg

W H D

Dimensions: 410 x 220 x 210 cm



CANTERBURY COMPOUND

Product Name: Canterbury
Compound Bike Shelter

20/40/60/80 bike compounds available

Product Description:

Bream and Code for Sustainable
Homes Compliant

This bike shelter can help contribute
towards gaining ENE8 Cycle storage
credits when used in the appropriate
situation, under the Code for
Sustainable Homes.

Specification :

Shelter manufactured from hot dipped
steel Galvanised 50 x 50 box section to
BSEN ISO1461

Transparent PET 4mm roof and sides

Aluminium fixing straps

All fixings to be galvanised or aluminium

Nyloc nuts are used for safety

Anti climb end panels

No crawl under perimeters

Angled roof

Rear security panel

Front security swinging gate

Padlock/Hasp locking mechanism
as standard, other locking options
available

Installation Notes

Base plate fixing

Submerged fixing

No Cycle racks provided

Additional Information - 20 bikes

W D H

Dimensions: 410 x 520 x 210 cm



LOCKERPOD+

The Lockerpod+ is the ideal bike parking locker solution for your home or business! Securing up to 4 bikes in a stylish design and manufactured in 100% recyclable material. The Lockerpod+ will keep your bikes secure and dry using a lot less space than your average shed!

The Lockerpod+ and +SS are the only Sold Secure Approved lockers in the UK!

The Lockerpod+ has a 3-point locking system and key operated door so you don't need to worry about padlocks! You can have the unit "free-standing" on grass/concrete etc or you may choose to bolt through the inside base onto a hard standing surface for extra security.



Product Name: Lockerpod+ is Sold Secure Bronze approved

Product Name: Lockerpod+SS is Sold Secure Gold approved

Material: Medium density polyethylene (MDPE), Green version is recycled and recyclable, where as colour versions are just recyclable.

Wall Thickness: 4-6 mm single skin rear, with door being 4-6mm double skin.

Finish: Standard colour Green, other colours available at additional cost.

Product Weight: Rear 60Kg, door 12kg.
Securing hinge: Galvanised Steel

Securing Lock: Multi 3 point locking mechanism

Fixings Material: 4 x Ground anchors, nickel plated.

Ground Fixings Required: 3 types: 16mm outer diameter shield anchor bolts drilled to a depth of 100mm max . Self using M14 Sheer off nuts and resin. 4 fixing bolt required per Lockerpod

Ground Type Required: Solid level base required. Concrete, large slabs with minimum 50mm thickness

Internal fixings: Hexagonal nuts or optional shear off nuts + Loc tight to be used on all internal fixings.

Additional Information

Dimensions: L 200 x W 100 x H 135cm

Product Finish: Recycled green, red, orange, dark green, yellow, light green, light blue, dark blue, brown, dark gray, black, white, light grey, millstone, white marble, granite, sandstone, green marble.

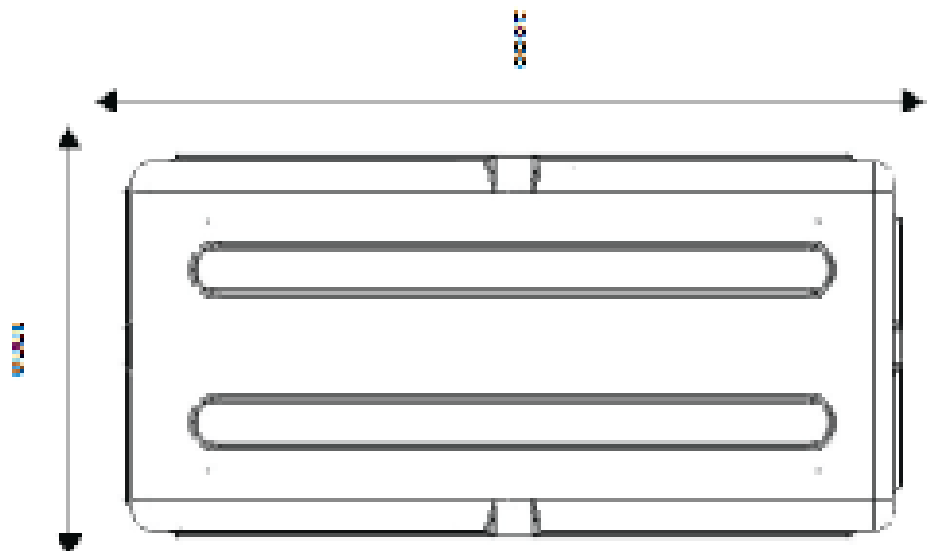
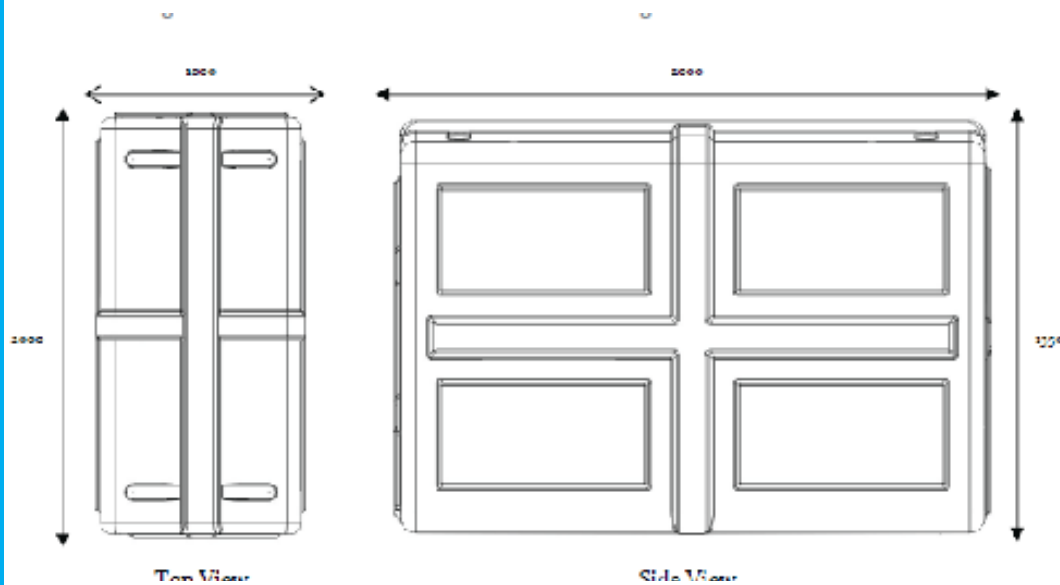
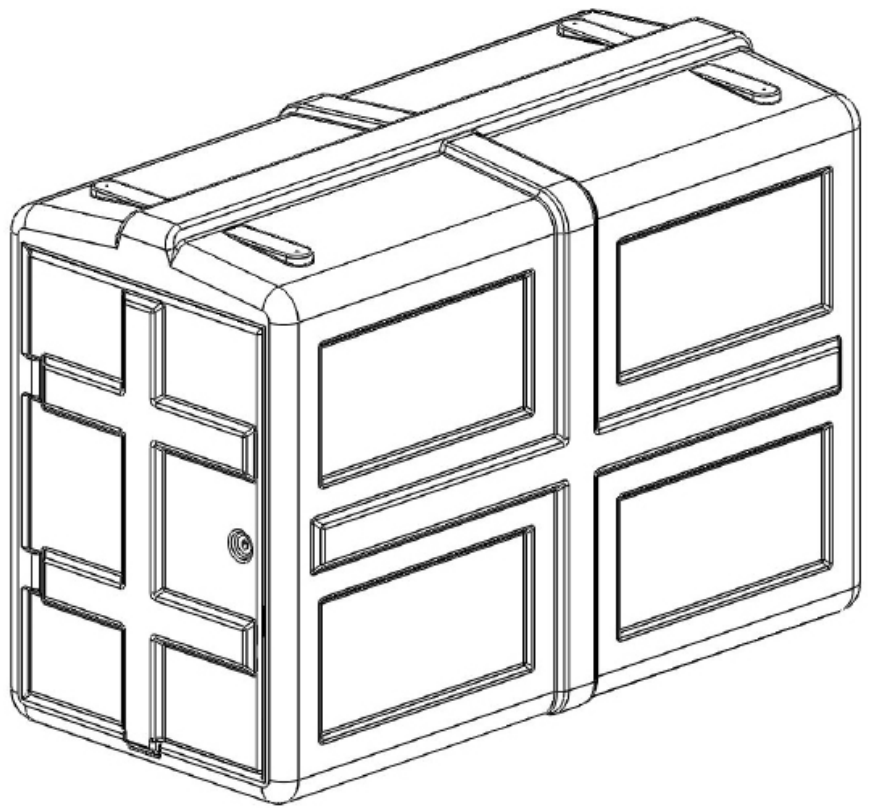

Testimonials

"The Minipods have attracted both children and parent's attention. The primary school children are using the pod situated in the playground and older siblings are being positively encouraged to bring their bikes/scooters to school and store in Minipods. Since the Minipods arrived the volume of 'Green' traffic has most definitely increased. So a very big thank you to all who have supported us.

P.S. Even staff are cycling to work!"

Kirsten Wilkie, School Travel Plan Coordinator, Renfrewshire Council

"We are absolutely delighted with our Minipods and I can't begin to tell you how popular they are. The children really enjoy coming to school on their bike and scooters and it's wonderful to see them arrive in the playground and take responsibility for parking them and locking them up. The Minipods are used across all our year groups, from Reception to Year 4 and even by the staff! They are just the right size and simple to use.

Only today I counted more than 45 bikes and scooters all neatly locked up. This means that almost a quarter of our entire roll arrived at school by this method of transport, quite an achievement.

I'm so pleased too we decided to go with the coloured pods – the red and blue pods are a bright and cheerful addition to our playground.

It has been a pleasure dealing with you right from my initial enquiry through to my order and our second order six months later. I must also praise your installers for their quick and efficient work and very kind attention. I would thoroughly recommend Minipods!"

Emma Morris, Parent Governor

"Ashburnham Community School, as part of its concern for the environment, has been looking for an eco-friendly cycle rack for staff and children. The Minipod was ordered on a Friday and installed within the week. It is eye-catching and has encouraged the staff to use their bikes to journey to school. It does not take up as much space as conventional racks.

There has been much comment from visitors to the school about the design and I would recommend this product and company to anyone looking for an eco-friendly solution to encourage cycling. The team at Cyclepods are friendly, efficient and extremely helpful.

Carol Keohane, Ashburnham Community School

Testimonials

"Although we haven't kept a record of numbers, I would say just be looking out the window in the morning there are around 50% more bikes and scooters! The children find them easy to use and the fact they are 100% recyclable is very important to us.

The Minipods were purchased through our green travel grant, therefore to have a product which encourage green travel but is also recyclable itself couldn't be better. We believe they are helping keep our children healthy by encouraging them to bike/scooter to school. Your installation team were so quiet and considerate; we didn't even know they were there!"

Mary Goldsmith, Loose Primary School

"We decided to explore what types of bicycle and scooter storage were available, how much storage we might need and where we would position it. Traditional 'bike sheds' were expensive, did not hold many bicycles, had no provision for scooters and we were concerned about potential vandalism. By chance, we came across Minipods and, with their innovative design, discovered we could store both bicycles and scooters together. The bright colours and child-friendliness of the pods were perfect for our age range.

As soon as the new storage was installed the number of children cycling to school immediately increased despite having them put in during the middle of winter. By the following summer term we had outgrown the existing number of Minipods and had to buy another one. From our annual 'hands-up' travel survey we have increased cycle usage from 1% to 14% at our school."

Potton Lower School

**CYCLEPODS LTD
2 BETSOMS BARN
PILGRIMS WAY
WESTERHAM
KENT
TN16 2DS**