

# eBike CHARGING STATION



**SARIS**  
INFRASTRUCTURE



Our eBike Charging Station is a public-use, universal eBike battery charging system that also provides a secure means of parking your bike. Designed to accommodate a wide range of personal eBike drive systems, each "charging dock" has a secure, user-accessible locker that contains a 120V/240V outlet for power access. Using their personal charger, users can safely store the charger inside the locker during charging.

## Product Specifications

- Available in worldwide power options 120V/240V; designed to be hardwired
- All units equipped with GFCI outlets
- Wheel wells accommodate 20" to 29" wheels and up to 5" tires
- Charging box door secured with padlock
- Active cooling system to prevent charger from overheating
- Can be installed indoors or outdoors with overhead protection
- User instructions on each unit
- UL/CE listed

# eBike Charging Station

## Site Layout

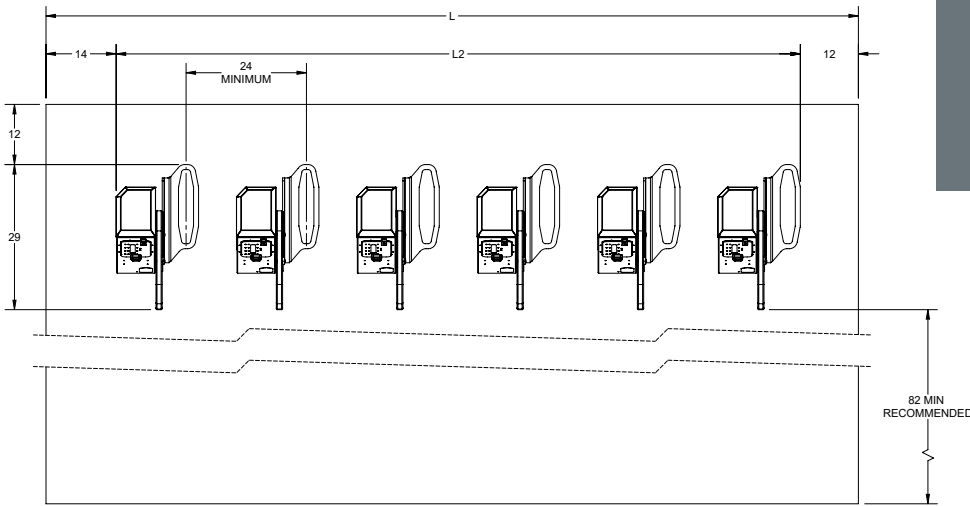

System Length		
# of Docks	"L"	"L2"
1	42	16
2	66	40
3	90	64
4	114	88
5	138	112
6	162	136
7	186	160
8	210	184

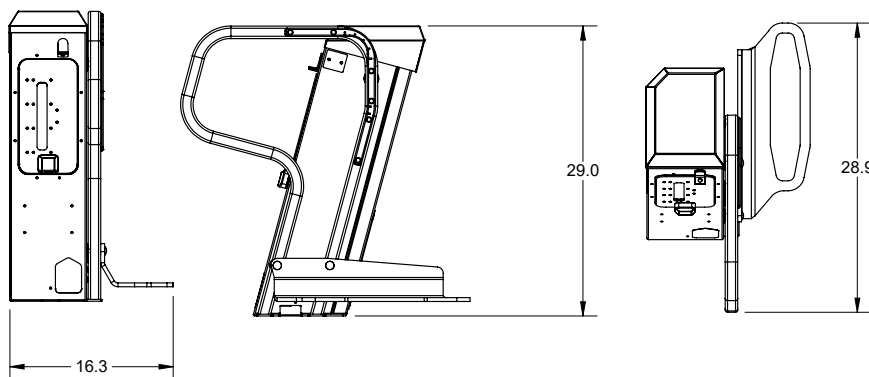

Part No.	Outlet configuration
84101320	USA/Canada Outlet
84201320	EU Outlet
84301320	UK Outlet
84401320	Australia/New Zealand Outlet



one Bike per charging dock



Can be installed indoors or outdoors with overhead cover



Recommended anchor: #28879



1 year warranty



Made in the USA



User Instruction included on each unit



Secure charging locker includes automatic cooling fan and GFCI outlet (charger not included)

Downloadable product resources available online:



CAD Files



SketchUp Files



Written Specs



Photos

